

MobilFlex

DJ motor (jackshaft)

MOTOR CHAMBERLAIN
 MODEL DJ501L5 1/2HP
 115V, 1PH, 60HZ, 11.2A
 MyQ TECHNOLOGY
 SECURITY+ 2.0
 WEIGHT: 100 LBS

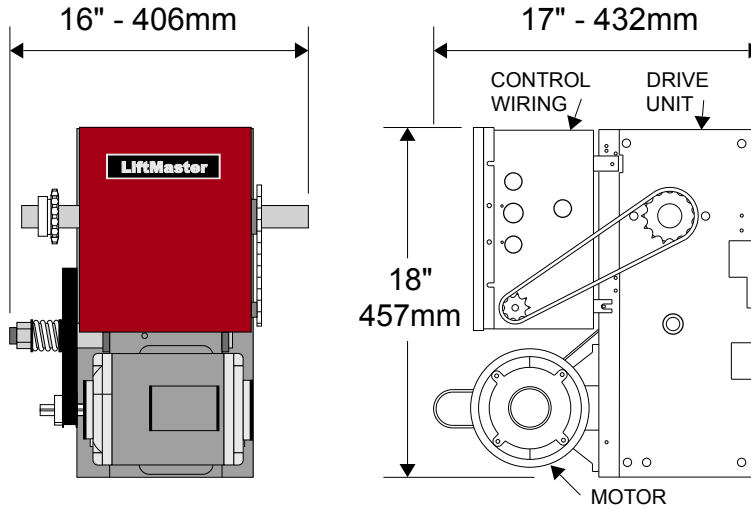

- Included with motor:
- Emergency release
 - Pushbutton station
 - Built-in interlocks
 - Photoelectric sensors

FACE OF COIL MOUNT

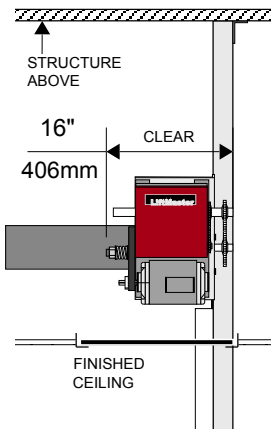
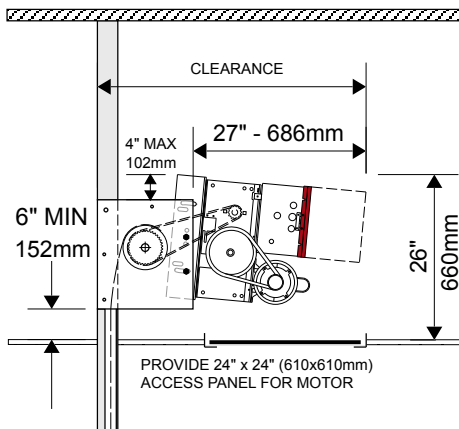

CONTROLS (24V):

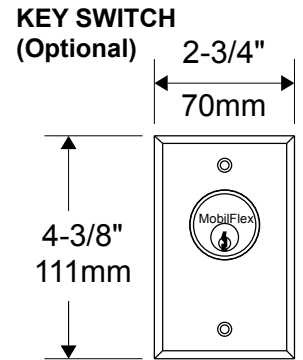
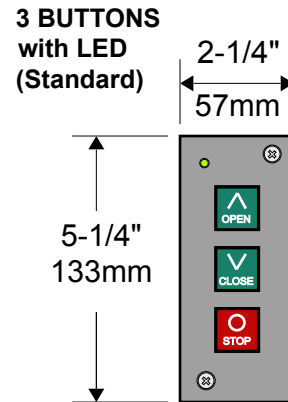

Constant pressure:
 OPEN or CLOSE
 Electrical connections
 by electrician

ABOVE COIL MOUNT

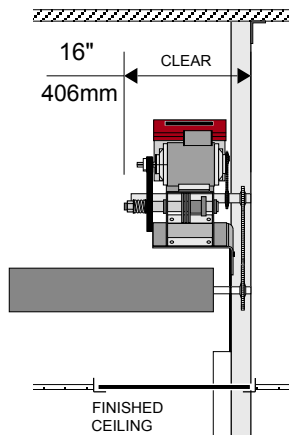
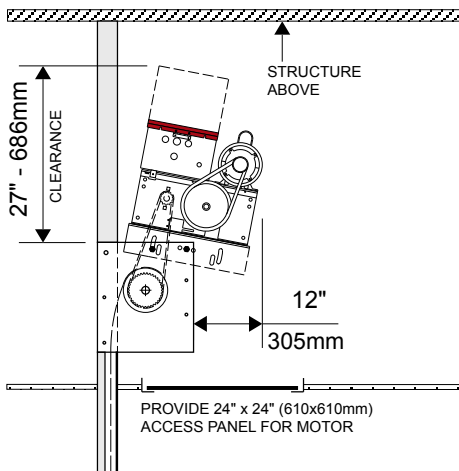

EMERGENCY RELEASE

