

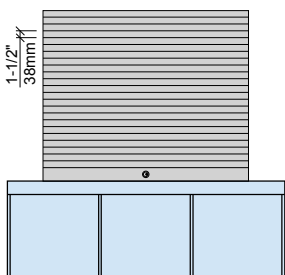

Easy to work with
Very competitive **Reliable**
Efficient customer service
Delivering a quality product, accurately & timely
Fast, friendly & affordable
Consistent

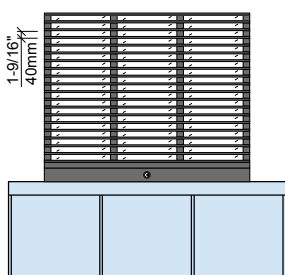

COUNTER SHUTTER
(Opaque)



SLIM ROLL-VISION
(Polycarbonate)

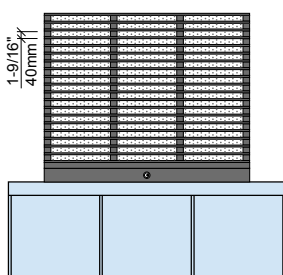

SLIM ROLL-AIR
(Perforated)

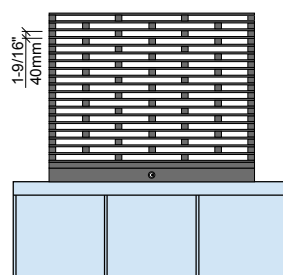

SLIM ROLL-FLEX
(Open style, brick)

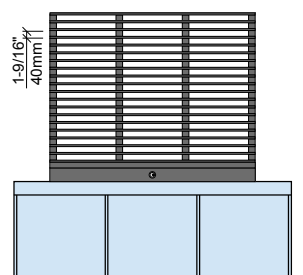

SLIM ROLL-FLEX
(Open style, straight)

COUNTER SHUTTER & SLIM MODELS

Max Curtain size 100sq.ft. - 9,3m²
 Max Width 16' - 4,88m or Max Height 12' - 3,66m

Guide installation:

For 8" x 8" (203 x 203mm) end plates:

1- FACE OF WALL

(attached through guide)

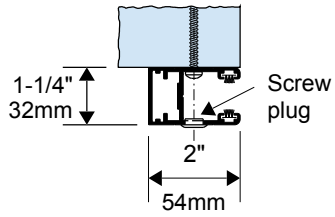

2- SURFACE MOUNTED

(between 2 walls)

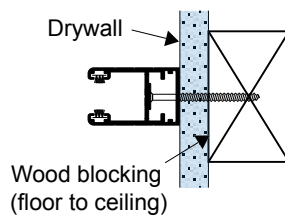

For 10" x 10" (254 x 254mm) end plates and for Tubular motor:

1- FACE OF WALL

(attached through guide)

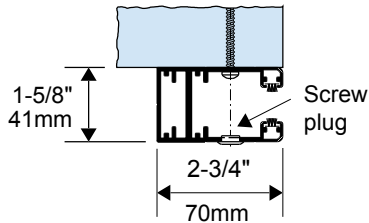

2- SURFACE MOUNTED

(between 2 walls)

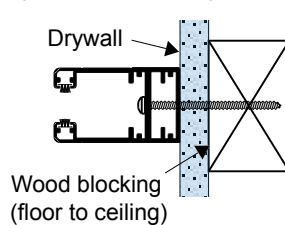

*** EASY INSTALL *
 SLIDE-IN END PLATES**

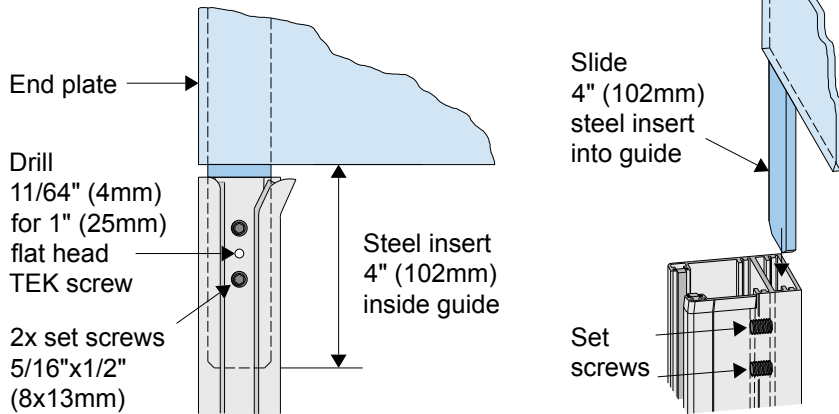

End plate sizes:

For 4 1/2" - 114mm dia Barrel (Manual) &
 4" - 102mm dia Barrel (Motorized)

CEILING HEIGHT		END PLATE
WITH HOOD	NO HOOD	
up to 6' 1,83m	up to 7' 2,13m	8" x 8" 203 x 203mm
6' to 10' 1,83m to 3,05m	7' to 12' 2,13m to 3,66m	10" x 10" 254 x 254mm

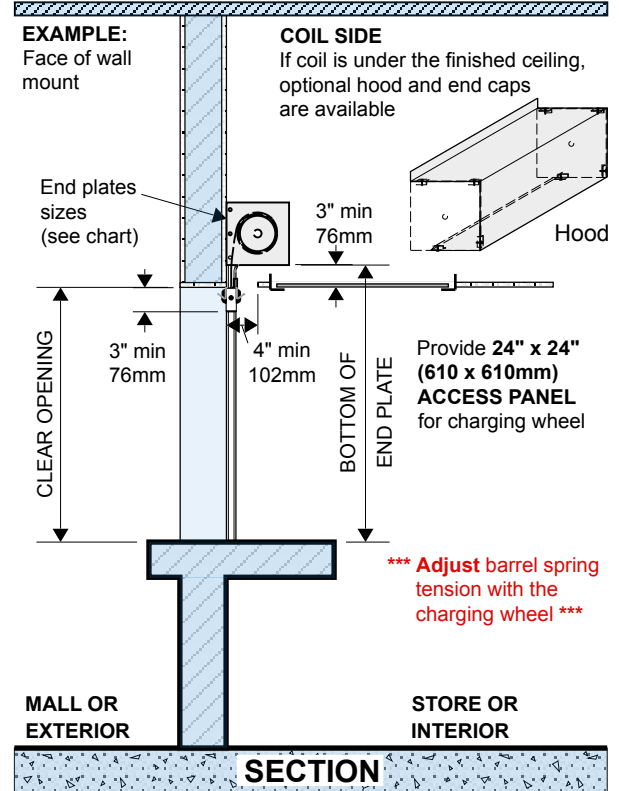

MODEL	lb / sq.ft	kg / m ²
SLIM ROLL-VISION	1,33	6,49
SLIM ROLL-AIR	1,52	7,42
SLIM ROLL-FLEX	1,08	5,27
SLIM ROLL-SHUTTER	1,69	8,25
COUNTER SHUTTER or CABINET SHUTTER	1,29	6,30

BOTTOM BAR

16' (4,88m) maximum width
 for center locking.

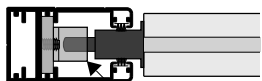

Turn key to engage bolts under stoppers inside guides

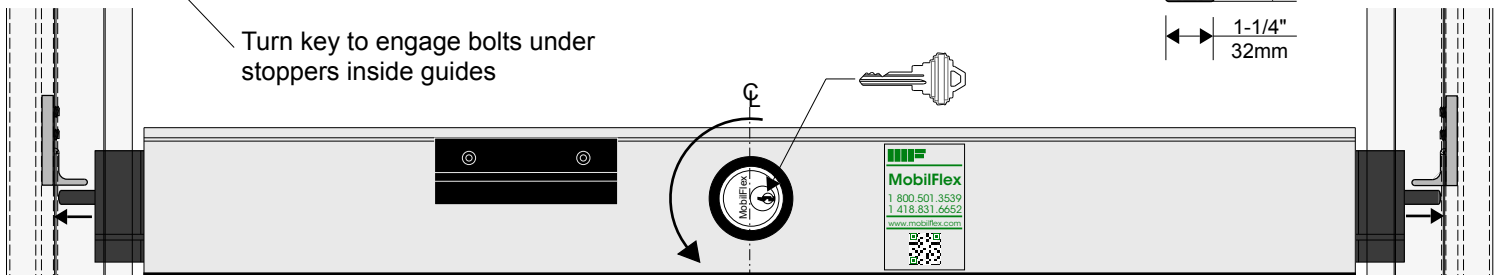

SECTION 2nd cylinder (optional)

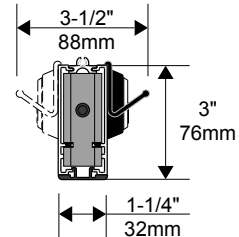

TUBULAR MOTOR

4" - 102mm dia Barrel

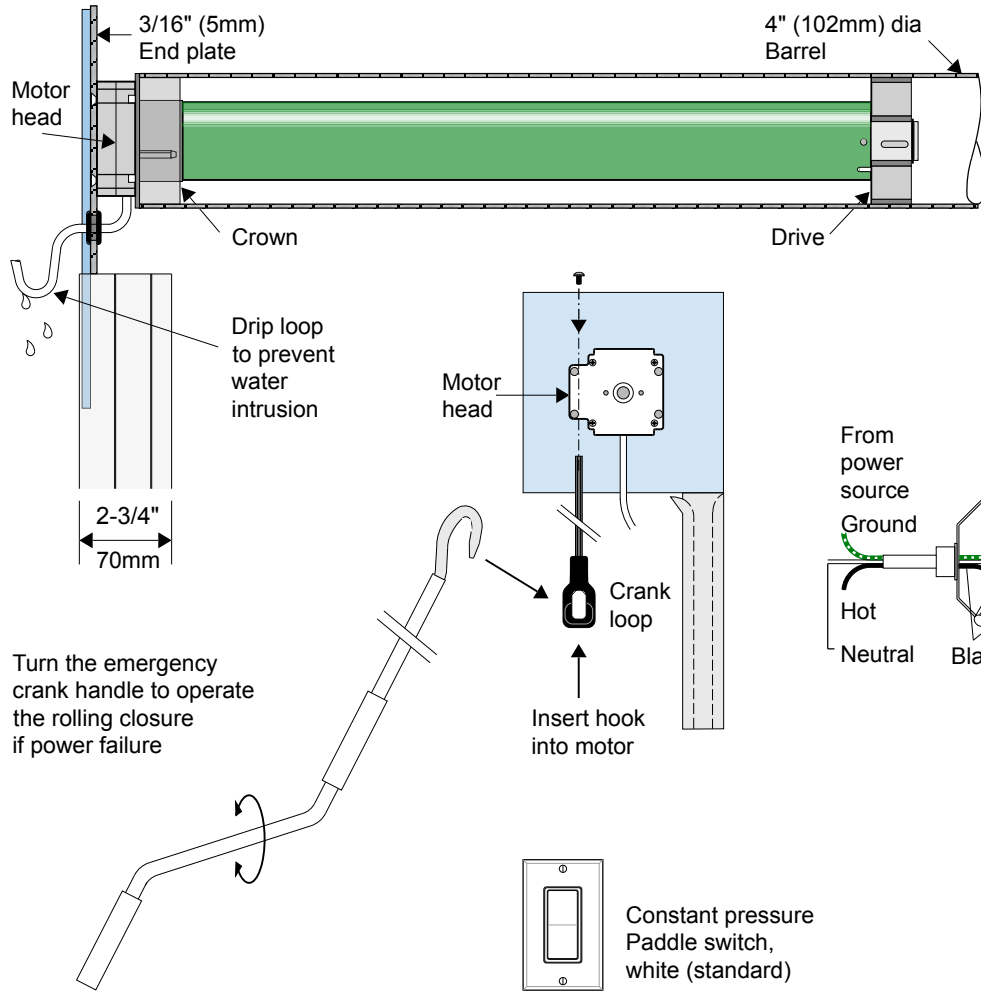

COUNTER SHUTTER

Operation options

Motor details:

- Torque 100 Nm, Speed 11 rpm
- 120 V Ac, 60 Hz, 2.94 A
- Mechanic Limit Adjustment
- Limit switch capacity: 22 turns maximum
- Thermal protection: 4 min running time
- 1:30 Gear ratio for manual override

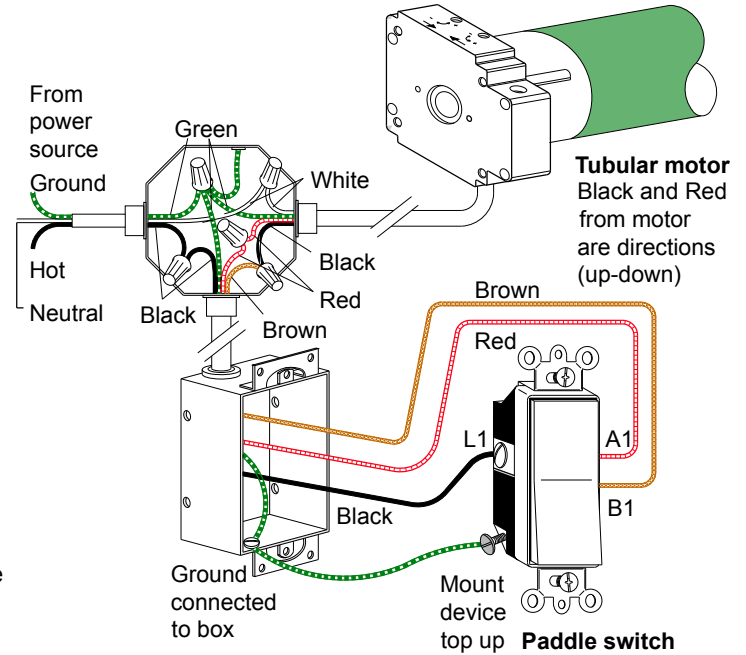

HAND CRANK

If shutter out of reach

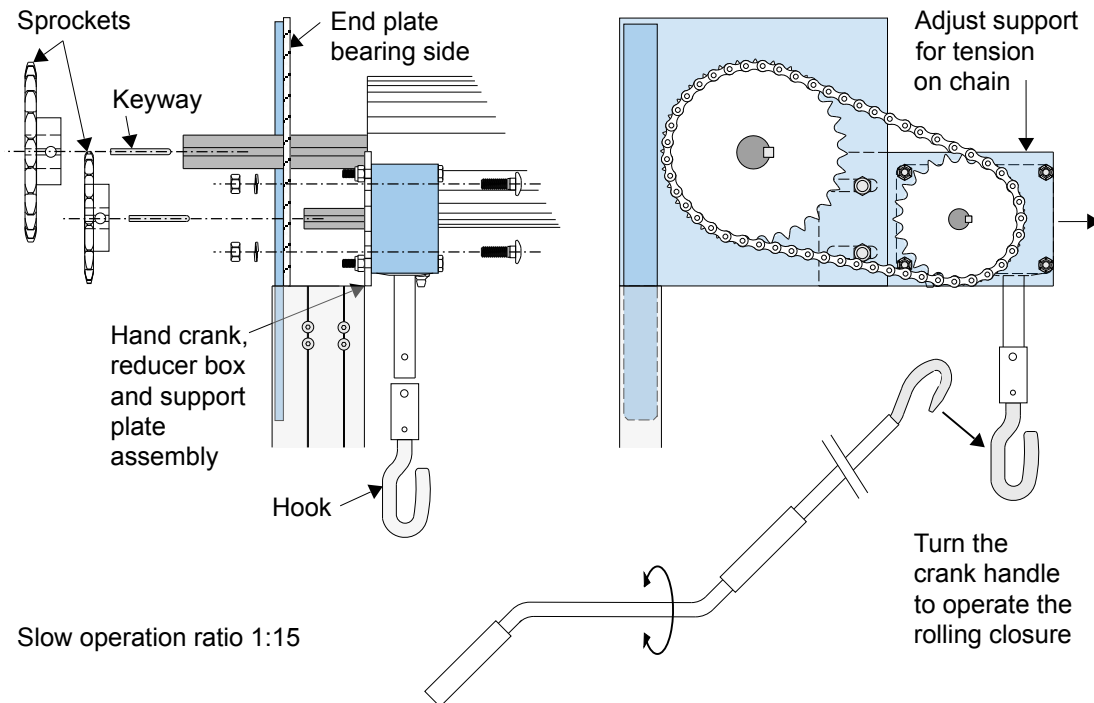

COLORS

Clear Anodized finish only for Counter & Cabinet Shutters

Standard colors for SLIM models:

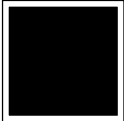
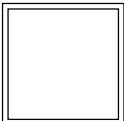
-  Clear Anodized
-  Acrylic Paint Black
-  Acrylic Paint White

Special color available at extra cost

CABINET SHUTTER

Max Curtain size 15sq.ft. - 1.4m²
 Width 24" - 610mm to 72" - 1830mm

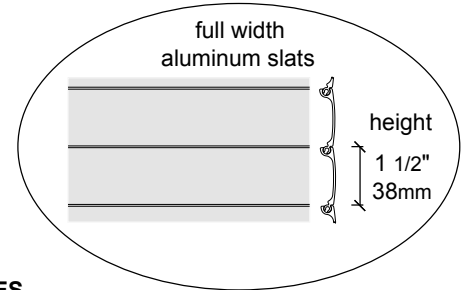
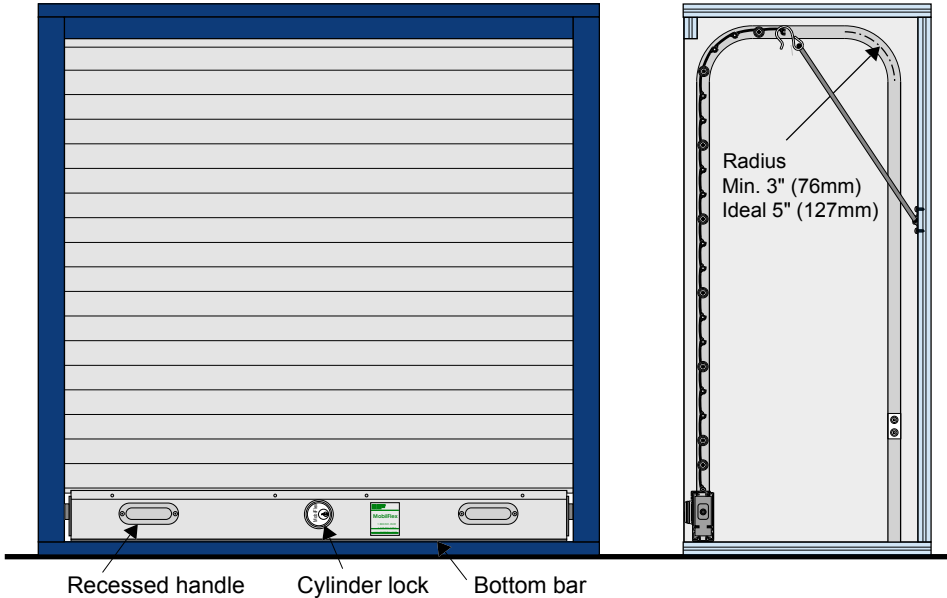

NOTES

MANUAL PUSH-UP

ALUMINUM GUIDES NOT REQUIRED
 MILLWORK GROOVES & LINING BY OTHERS

**PROVIDE ACCESS AT BACK OF CABINET
 FOR INSTALLATION AND SERVICE**

ADJUST BUNGEE CORD LENGTH
 FOR PROPER TENSION

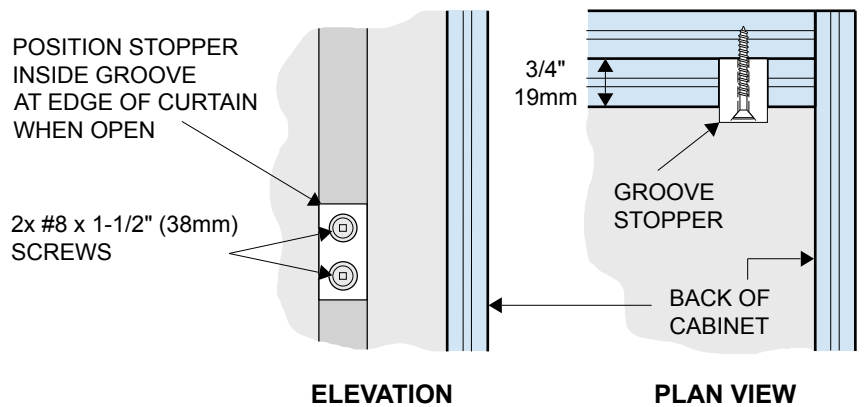
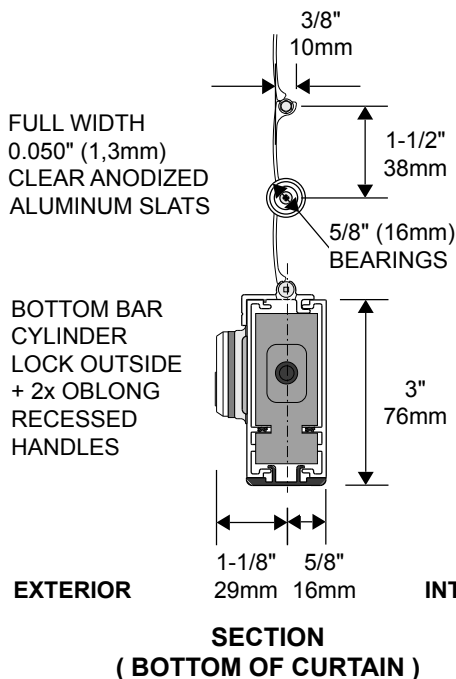
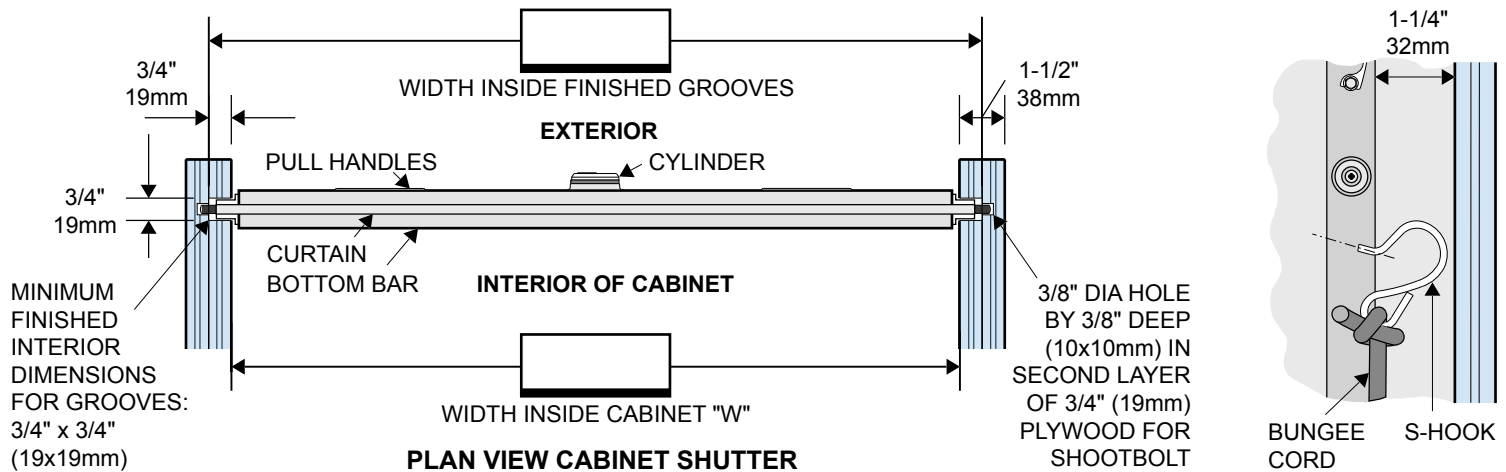

CANADA

TEL: 1. 800. 501. FLEX (3539)

Web site: www.mobilflex.com

UNITED STATES

TEL: 1. 800. 216. FLEX (3539)

E-mail: flex@mobilflex.com